

BEST AVAILABLE COPY

(12) INTERNATIONAL APPLICATION PUBLISHED UNDER THE PATENT COOPERATION TREATY (PCT)

(19) World Intellectual Property Organization  
International Bureau



(43) International Publication Date  
16 January 2003 (16.01.2003)

PCT

(10) International Publication Number  
WO 03/004819 A2

- (51) International Patent Classification<sup>7</sup>: E21B
- (21) International Application Number: PCT/US02/20256
- (22) International Filing Date: 26 June 2002 (26.06.2002)
- (25) Filing Language: English
- (26) Publication Language: English
- (30) Priority Data: 60/303,740 6 July 2001 (06.07.2001) US
- (71) Applicant (for all designated States except US): ENVENTURE GLOBAL TECHNOLOGY [US/US]; 16200 A. Park Row, Houston, TX 77084 (US).
- (72) Inventors; and
- (75) Inventors/Applicants (for US only): COOK, Robert, Lance [US/US]; 934 Caswell Court, Katy, TX 77450 (US). RING, Lev [RU/US]; 14126 Heatherhill Place, Houston,

- TX 77077 (US). BRISCO, David, Paul [US/US]; 405 Westridge Drive, Duncan, OK 73533 (US).
- (74) Agents: MATTINGLY, Todd et al.; Haynes & Boone, LLP, Suite 4300, 1000 Louisiana Street, Houston, TX 77002-5012 (US).
- (81) Designated States (national): AE, AG, AL, AM, AT, AU, AZ, BA, BB, BG, BR, BY, BZ, CA, CH, CN, CO, CR, CU, CZ, DE, DK, DM, DZ, EC, EE, ES, FI, GB, GD, GE, GH, GM, HR, HU, ID, IL, IN, IS, JP, KE, KG, KP, KR, KZ, LC, LK, LR, LS, LT, LU, LV, MA, MD, MG, MK, MN, MW, MX, MZ, NO, NZ, PH, PL, PT, RO, RU, SD, SE, SG, SI, SK, SL, TJ, TM, TR, TT, TZ, UA, UG, US, UZ, VN, YU, ZA, ZW.
- (84) Designated States (regional): ARIPO patent (GH, GM, KE, LS, MW, MZ, SD, SL, SZ, TZ, UG, ZM, ZW), Eurasian patent (AM, AZ, BY, KG, KZ, MD, RU, TJ, TM), European patent (AT, BE, CH, CY, DE, DK, ES, FI, FR,

[Continued on next page]



(54) Title: LINER HANGER

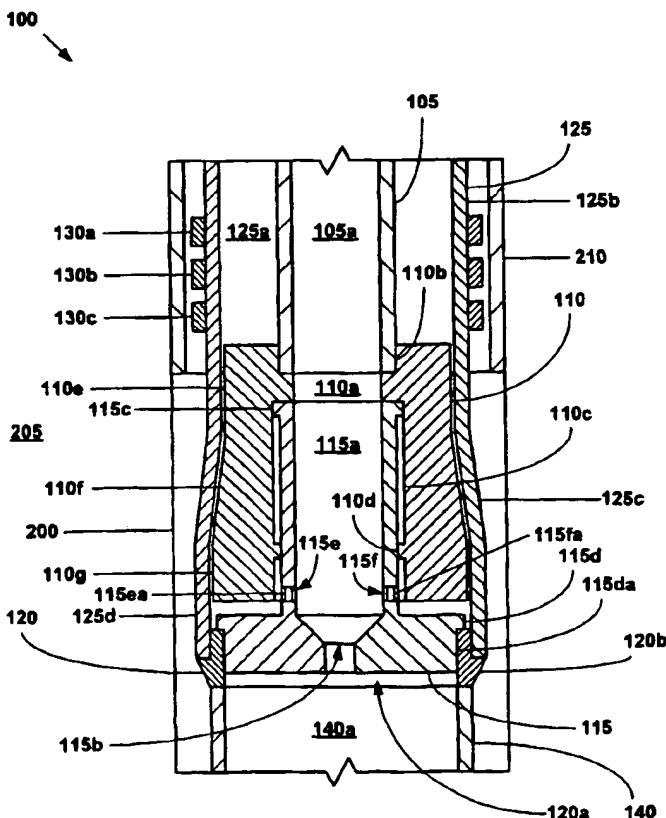

(57) Abstract: An apparatus and method for forming or repairing a wellbore casing by radially expanding a tubular liner.

WO 03/004819 A2



GB, GR, IE, IT, LU, MC, NL, PT, SE, TR), OAPI patent  
(BF, BJ, CF, CG, CI, CM, GA, GN, GQ, GW, ML, MR,  
NE, SN, TD, TG).

**Published:**

— without international search report and to be republished  
upon receipt of that report

**Declaration under Rule 4.17:**

— of inventorship (Rule 4.17(iv)) for US only

For two-letter codes and other abbreviations, refer to the "Guidance Notes on Codes and Abbreviations" appearing at the beginning of each regular issue of the PCT Gazette.

## LINER HANGER

## Cross Reference To Related Applications

This application claims the benefit of the filing date of U.S. provisional patent application serial no. 60/303,740, attorney docket no. 25791.61, filed on 7/6/2001, the disclosure of which is  
5 incorporated herein by reference.

This application is related to the following: (1) U.S. patent application serial no. 09/454,139, attorney docket no. 25791.03.02, filed on 12/3/1999, (2) U.S. patent application serial no. 09/510,913, attorney docket no. 25791.7.02, filed on 2/23/2000, (3) U.S. patent application serial no. 09/502,350, attorney docket no. 25791.8.02, filed on 2/10/2000, (4) U.S. patent application serial no. 09/440,338,  
10 attorney docket no. 25791.9.02, filed on 11/15/1999, (5) U.S. patent application serial no. 09/523,460, attorney docket no. 25791.11.02, filed on 3/10/2000, (6) U.S. patent application serial no. 09/512,895, attorney docket no. 25791.12.02, filed on 2/24/2000, (7) U.S. patent application serial no. 09/511,941, attorney docket no. 25791.16.02, filed on 2/24/2000, (8) U.S. patent application serial no. 09/588,946, attorney docket no. 25791.17.02, filed on 6/7/2000, (9) U.S. patent application serial no. 09/559,122,  
15 attorney docket no. 25791.23.02, filed on 4/26/2000, (10) PCT patent application serial no. PCT/US00/18635, attorney docket no. 25791.25.02, filed on 7/9/2000, (11) U.S. provisional patent application serial no. 60/162,671, attorney docket no. 25791.27, filed on 11/1/1999, (12) U.S. provisional patent application serial no. 60/154,047, attorney docket no. 25791.29, filed on 9/16/1999, (13) U.S. provisional patent application serial no. 60/159,082, attorney docket no. 25791.34, filed on  
20 10/12/1999, (14) U.S. provisional patent application serial no. 60/159,039, attorney docket no. 25791.36, filed on 10/12/1999, (15) U.S. provisional patent application serial no. 60/159,033, attorney docket no. 25791.37, filed on 10/12/1999, (16) U.S. provisional patent application serial no. 60/212,359, attorney docket no. 25791.38, filed on 6/19/2000, (17) U.S. provisional patent application serial no. 60/165,228, attorney docket no. 25791.39, filed on 11/12/1999, (18) U.S. provisional patent  
25 application serial no. 60/221,443, attorney docket no. 25791.45, filed on 7/28/2000, (19) U.S. provisional patent application serial no. 60/221,645, attorney docket no. 25791.46, filed on 7/28/2000, (20) U.S. provisional patent application serial no. 60/233,638, attorney docket no. 25791.47, filed on 9/18/2000, (21) U.S. provisional patent application serial no. 60/237,334, attorney docket no. 25791.48, filed on 10/2/2000, (22) U.S. provisional patent application serial no. 60/270,007, attorney  
30 docket no. 25791.50, filed on 2/20/2001; (23) U.S. provisional patent application serial no. 60/262,434, attorney docket no. 25791.51, filed on 1/17/2001; (24) U.S. provisional patent application serial no. 60/259,486, attorney docket no. 25791.52, filed on 1/3/2001; and (25) U.S. provisional patent application serial no. 60/303,711, attorney docket no. 25791.44, filed on 7/6/01, the disclosures of which are incorporated herein by reference.

### Background of the Invention

This invention relates generally to wellbore casings, and in particular to wellbore casings that are formed using expandable tubing.

Conventionally, when a wellbore is created, a number of casings are installed in the borehole to prevent collapse of the borehole wall and to prevent undesired outflow of drilling fluid into the formation or inflow of fluid from the formation into the borehole. The borehole is drilled in intervals whereby a casing which is to be installed in a lower borehole interval is lowered through a previously installed casing of an upper borehole interval. As a consequence of this procedure the casing of the lower interval is of smaller diameter than the casing of the upper interval. Thus, the casings are in a nested arrangement with casing diameters decreasing in downward direction. Cement annuli are provided between the outer surfaces of the casings and the borehole wall to seal the casings from the borehole wall. As a consequence of this nested arrangement a relatively large borehole diameter is required at the upper part of the wellbore. Such a large borehole diameter involves increased costs due to heavy casing handling equipment, large drill bits and increased volumes of drilling fluid and drill cuttings. Moreover, increased drilling rig time is involved due to required cement pumping, cement hardening, required equipment changes due to large variations in hole diameters drilled in the course of the well, and the large volume of cuttings drilled and removed.

The present invention is directed to overcoming one or more of the limitations of the existing procedures for forming wellbores and wellheads.

### Summary of the Invention

According to one aspect of the present invention, a method of coupling a radially expandable tubular member to a preexisting structure is provided that includes positioning the tubular member within the preexisting structure, injecting fluidic materials into the tubular member, sensing the operating pressure of the fluidic materials, and radially expanding and plastically deforming the tubular member into contact with the preexisting structure when the sensed operating pressure exceeds a predetermined amount.

According to another aspect of the present invention, an apparatus for coupling a radially expandable tubular member to a preexisting structure is provided that includes a tubular support member including a first passage, a tubular expansion cone coupled to the tubular support member defining a second passage and including an internal flange, a tubular shoe movably received within the second passage of the tubular expansion cone defining one or more radial passages and a valveable passage fluidically coupled to the first passage and including an external flange for engaging the internal flange, one or more pressure relief valves positioned in corresponding ones of the radial passages, and an expandable tubular member movably coupled to the tubular expansion cone.

According to another aspect of the present invention, a system for coupling a radially expandable tubular member to a preexisting structure is provided that includes means for positioning the tubular member within the preexisting structure, means for injecting fluidic materials into the

tubular member, means for sensing the operating pressure of the fluidic materials, and means for radially expanding the tubular member into contact with the preexisting structure when the sensed operating pressure exceeds a predetermined amount.

#### Brief Description of the Drawings

5 Fig. 1 is a fragmentary cross-sectional illustration of an embodiment of a liner hanger positioned within a wellbore including a preexisting section of wellbore casing.

Fig. 2 is a fragmentary cross-sectional illustration of the injection of a fluidic material into the apparatus of Fig. 2.

10 Fig. 3 is a fragmentary cross-sectional illustration of the placement of a ball into the valveable passage of the tubular shoe of the apparatus of Fig. 2.

Fig. 4 is a fragmentary cross-sectional illustration of the continued injection of the fluidic material into the apparatus of Fig. 3 in order to burst the burst discs.

15 Fig. 5 is a fragmentary cross-sectional illustration of the continued injection of the fluidic material into the apparatus of Fig. 4 in order to plastically deform and radially expand the expandable tubular member.

Fig. 6 is a fragmentary cross-sectional illustration of the completion of the radial expansion and plastic deformation of the expandable tubular member of the apparatus of Fig. 5.

#### Detailed Description of the Illustrative Embodiments

20 An apparatus and method for plastically deforming a tubular liner within a wellbore within a subterranean formation is provided. The apparatus and method thereby provides a system for coupling a radially expandable tubular liner to an open hole or cased section of a wellbore within a subterranean formation. Furthermore, in this manner, a wellbore casing, a pipeline, or a structural support may be formed or repaired using the present illustrative embodiments.

25 Referring initially to Fig. 1, an embodiment of an apparatus 100 for radially expanding and plastically deforming a tubular liner includes a tubular support member 105 that defines a passage 105a that is coupled to a tubular expansion cone 110 that defines a passage 110a and includes a recess 110b for mating with and receiving the tubular support member 105, a recess 110c, and an internal flange 110d. The tubular expansion cone 110 further includes a first section 110e having a substantially cylindrical outer surface, a second section 110f having a substantially tapered conical outer surface, and a third section 110g having a substantially cylindrical outer surface. In an exemplary embodiment, the outside diameter of the first section 110e is greater than the outside diameter of the third section 110g. In an exemplary embodiment, the recess 110b includes internal threads and the end of the tubular support member 105 that is received within the recess 110b includes external threads for engaging the internal threads.

35 An end of a tubular shoe 115 mates with and is movably received within the recess 110c of the tubular expansion cone 110 that defines a passage 115a and a valveable passage 115b and includes an external flange 115c, and an external flange 115d including a recessed portion 115da. The tubular

shoe 115 further includes radial passages 115e and 115f for receiving corresponding burst discs, 115ea and 115fa. An end of a tubular support member 120 that defines a passage 120a mates with and is movably received within the recess 115da of the external flange 115d of the tubular shoe 115 and includes an external flange 120b having a substantially conical outer surface.

5 An end of an expandable tubular member 125 mates with and is coupled to the tubular support member 120 that defines a passage 125a for receiving the tubular support member 105, the tubular expansion cone 110, and the tubular shoe 115. In an exemplary embodiment, the end of the expandable tubular member 125 is coupled to the tubular support member 120 by a conventional threaded connection. In an exemplary embodiment, the expandable tubular member 125 includes a  
10 first section 125b having a substantially cylindrical outer surface, a second section 125c having a substantially conical outer surface, and a third section 125d having a substantially cylindrical outer surface. In an exemplary embodiment, the outside diameter of the first section 125b is greater than the outside diameter of the third section 125d. a plurality of tubular sealing members, 130a, 130b, and 130c, are coupled to the external surface of the first section 125b of the expandable tubular member  
15 125.

An end of a tubular member 140 that defines a passage 140a is coupled to an end of the tubular support member 120. In an exemplary embodiment, the connection between the tubular member 140 and the tubular support member 120 is a conventional threaded connection.

20 In an exemplary embodiment, as illustrated in Fig. 1, the apparatus 100 may be positioned within a wellbore 200 within a subterranean formation 205 that includes a preexisting section of wellbore casing 210. The wellbore 200 may be vertical, horizontal, or an intermediate orientation.

As illustrated in Fig. 2, a fluidic material 215 may then be injected into the apparatus 100 through the passages 105a, 110a, 115a, 115b, and 140a in order to ensure the proper operation of the passages. In an alternative embodiment, before or after the injection of the fluidic material 215, a  
25 hardenable fluidic sealing material such as, for example, cement, may be injected into the apparatus 100, through the passages 105a, 110a, 115a, 115b, and 140a, in order to form an annular body of a fluidic sealing material between the tubular member 125 and the wellbore 200.

As illustrated in Fig. 3, a ball 220 may then be placed into the valveable passage 115b of the tubular shoe 115 by introducing the ball into the injected fluidic material 215. In this manner, the  
30 valveable passage 115b of the tubular shoe 115 may be sealed off thereby permitting the passage 115a to be pressurized by the continued injection of the fluidic material 215.

As illustrated in Fig. 4, the continued injection of the fluidic material 215 will burst the burst discs 115ea and 115fa thereby permitting the injected fluidic material to pass through the radial passages 115e and 115f into the annular region between the tubular shoe 115 and the expandable  
35 tubular member 125 below the tubular expansion cone 110 above the external flange 115d of the tubular shoe.

As illustrated in Fig. 5, the continued injection of the fluidic material 215 will continue to

pressurize the annular region, between the tubular shoe 115 and the expandable tubular member 125 below the tubular expansion cone 110 above the external flange 115d of the tubular shoe, and thereby extrude the expandable tubular member 125 off of the tubular expansion cone 110 by plastically deforming and radially expanding the expandable tubular member.

5           During the continued radial expansion of the expandable tubular member 125, the tubular support member 105 and the tubular expansion cone 110 may be raised out of the wellbore 200. Because the tubular expansion cone 110 and the tubular shoe 115 are movably coupled, the axial displacement of the tubular expansion cone 110 during the radial expansion of the tubular member 125 does not displace the tubular shoe in the axial direction. In an exemplary embodiment, during the  
10 radial expansion and plastic deformation of the expandable tubular member 125, the tubular shoe 120 is supported by the tubular support member 120 in the axial direction.

          In an exemplary embodiment, the radial expansion of the expandable tubular member 125 further causes the sealing members, 130a, 130b, and 130c, to engage the preexisting wellbore casing 210. In this manner, the radially expanded tubular member 125, the tubular support member 120, and  
15 the tubular member 140 are coupled to the preexisting wellbore casing. Furthermore, in this manner, a fluidic seal is provided between the radially expanded tubular member 125 and the preexisting wellbore casing 210.

          As illustrated in Fig. 6, once the radial expansion of the expandable tubular member 125 has been completed, the tubular support member 105, the tubular expansion cone 110, and the tubular  
20 shoe 115 are removed from the wellbore 200. In particular, the external flange 115c of the tubular shoe 115 engages the internal flange 110d of the tubular expansion cone 110 thereby permitting the tubular shoe to be removed from the wellbore 200.

          In a preferred embodiment, the apparatus 100, and method of operating the apparatus, is provided substantially as disclosed in one or more of the following: (1) U.S. patent application serial  
25 no. 09/454,139, attorney docket no. 25791.03.02, filed on 12/3/1999, (2) U.S. patent application serial no. 09/510,913, attorney docket no. 25791.7.02, filed on 2/23/2000, (3) U.S. patent application serial no. 09/502,350, attorney docket no. 25791.8.02, filed on 2/10/2000, (4) U.S. patent application serial no. 09/440,338, attorney docket no. 25791.9.02, filed on 11/15/1999, (5) U.S. patent application serial  
30 no. 09/523,460, attorney docket no. 25791.11.02, filed on 3/10/2000, (6) U.S. patent application serial no. 09/512,895, attorney docket no. 25791.12.02, filed on 2/24/2000, (7) U.S. patent application serial no. 09/511,941, attorney docket no. 25791.16.02, filed on 2/24/2000, (8) U.S. patent application serial no. 09/588,946, attorney docket no. 25791.17.02, filed on 6/7/2000, (9) U.S. patent application serial  
35 no. 09/559,122, attorney docket no. 25791.23.02, filed on 4/26/2000, (10) PCT patent application serial no. PCT/US00/18635, attorney docket no. 25791.25.02, filed on 7/9/2000, (11) U.S. provisional patent application serial no. 60/162,671, attorney docket no. 25791.27, filed on 11/1/1999, (12) U.S. provisional patent application serial no. 60/154,047, attorney docket no. 25791.29, filed on 9/16/1999, (13) U.S. provisional patent application serial no. 60/159,082, attorney docket no. 25791.34, filed on

10/12/1999, (14) U.S. provisional patent application serial no. 60/159,039, attorney docket no. 25791.36, filed on 10/12/1999, (15) U.S. provisional patent application serial no. 60/159,033, attorney docket no. 25791.37, filed on 10/12/1999, (16) U.S. provisional patent application serial no. 60/212,359, attorney docket no. 25791.38, filed on 6/19/2000, (17) U.S. provisional patent application serial no. 60/165,228, attorney docket no. 25791.39, filed on 11/12/1999, (18) U.S. provisional patent application serial no. 60/221,443, attorney docket no. 25791.45, filed on 7/28/2000, (19) U.S. provisional patent application serial no. 60/221,645, attorney docket no. 25791.46, filed on 7/28/2000, (20) U.S. provisional patent application serial no. 60/233,638, attorney docket no. 25791.47, filed on 9/18/2000, (21) U.S. provisional patent application serial no. 60/237,334, attorney docket no. 25791.48, filed on 10/2/2000, (22) U.S. provisional patent application serial no. 60/270.007, attorney docket no. 25791.50, filed on 2/20/2001; (23) U.S. provisional patent application serial no. 60/262,434, attorney docket no. 25791.51, filed on 1/17/2001; (24) U.S. provisional patent application serial no. 60/259,486, attorney docket no. 25791.52, filed on 1/3/2001; and (25) U.S. provisional patent application serial no. 60/303,711, attorney docket no. 25791.44, filed on 7/6/01, the disclosures of which are incorporated herein by reference.

It is understood that variations may be made in the foregoing without departing from the scope of the invention. For example, the apparatus 100 may be used to form and/or repair, for example, a wellbore casing, a pipeline, or a structural support. Furthermore, the burst discs 115ea and 115fa may be replaced with conventional pressure relief valves.

Although illustrative embodiments of the invention have been shown and described, a wide range of modification, changes and substitution is contemplated in the foregoing disclosure. In some instances, some features of the present invention may be employed without a corresponding use of the other features. Accordingly, it is appropriate that the appended claims be construed broadly and in a manner consistent with the scope of the invention.



## Claims

- 1 1. A method of coupling a radially expandable tubular member to a preexisting structure,  
2 comprising:  
3 positioning the tubular member within the preexisting structure;  
4 injecting fluidic materials into the tubular member;  
5 sensing the operating pressure of the fluidic materials; and  
6 radially expanding and plastically deforming the tubular member into contact with the  
7 preexisting structure when the sensed operating pressure exceeds a predetermined  
8 amount.
- 1 2. The method of claim 1, wherein sensing the operating pressure includes:  
2 sensing the operating pressure of the fluidic materials within the tubular member.
- 1 3. The method of claim 1, further comprising:  
2 radially expanding and plastically deforming the tubular member using a tubular expansion  
3 cone; and  
4 movably coupling a tubular shoe to the tubular expansion cone.
- 1 4. An apparatus for coupling a radially expandable tubular member to a preexisting structure,  
2 comprising:  
3 a tubular support member including a first passage;  
4 a tubular expansion cone coupled to the tubular support member defining a second passage  
5 and including an internal flange;  
6 a tubular shoe movably received within the second passage of the tubular expansion cone  
7 defining one or more radial passages and a valveable passage fluidically coupled to the  
8 first passage and including an external flange for engaging the internal flange;  
9 one or more pressure relief valves positioned in corresponding ones of the radial passages;  
10 and an expandable tubular member movably coupled to the tubular expansion cone.
- 1 5. A system for coupling a radially expandable tubular member to a preexisting structure,  
2 comprising:  
3 means for positioning the tubular member within the preexisting structure;  
4 means for injecting fluidic materials into the tubular member;  
5 means for sensing the operating pressure of the fluidic materials; and

6 means for radially expanding the tubular member into contact with the preexisting structure  
7 when the sensed operating pressure exceeds a predetermined amount.

1 6. The system of claim 5, wherein the means for sensing the operating pressure includes:  
2 means for sensing the operating pressure of the fluidic materials within the tubular member.

1 7. The system of claim 5, further comprising:  
2 means for radially expanding and plastically deforming the tubular member using a tubular  
3 expansion cone; and  
4 means for movably coupling a tubular shoe to the tubular expansion cone.

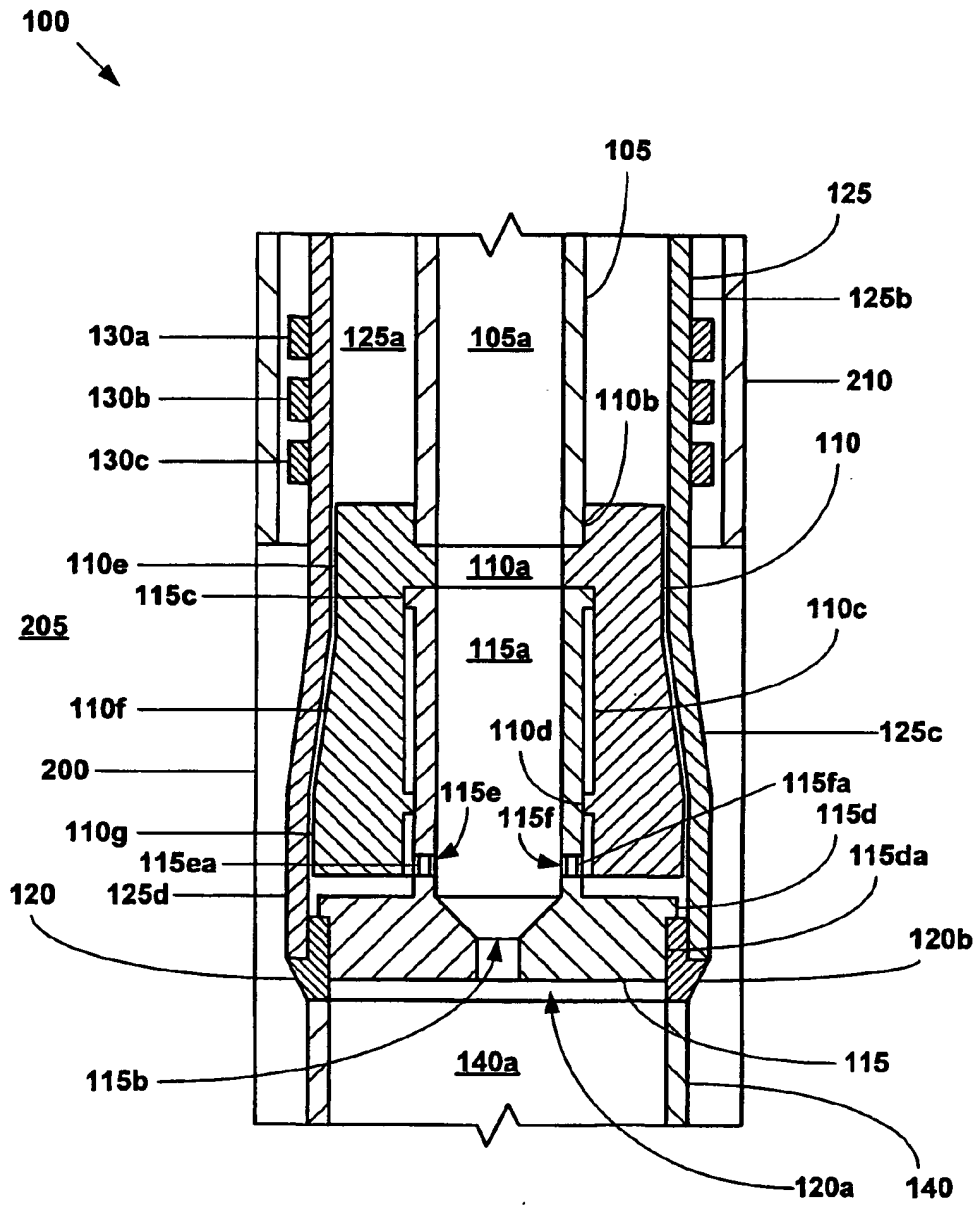

Fig. 1

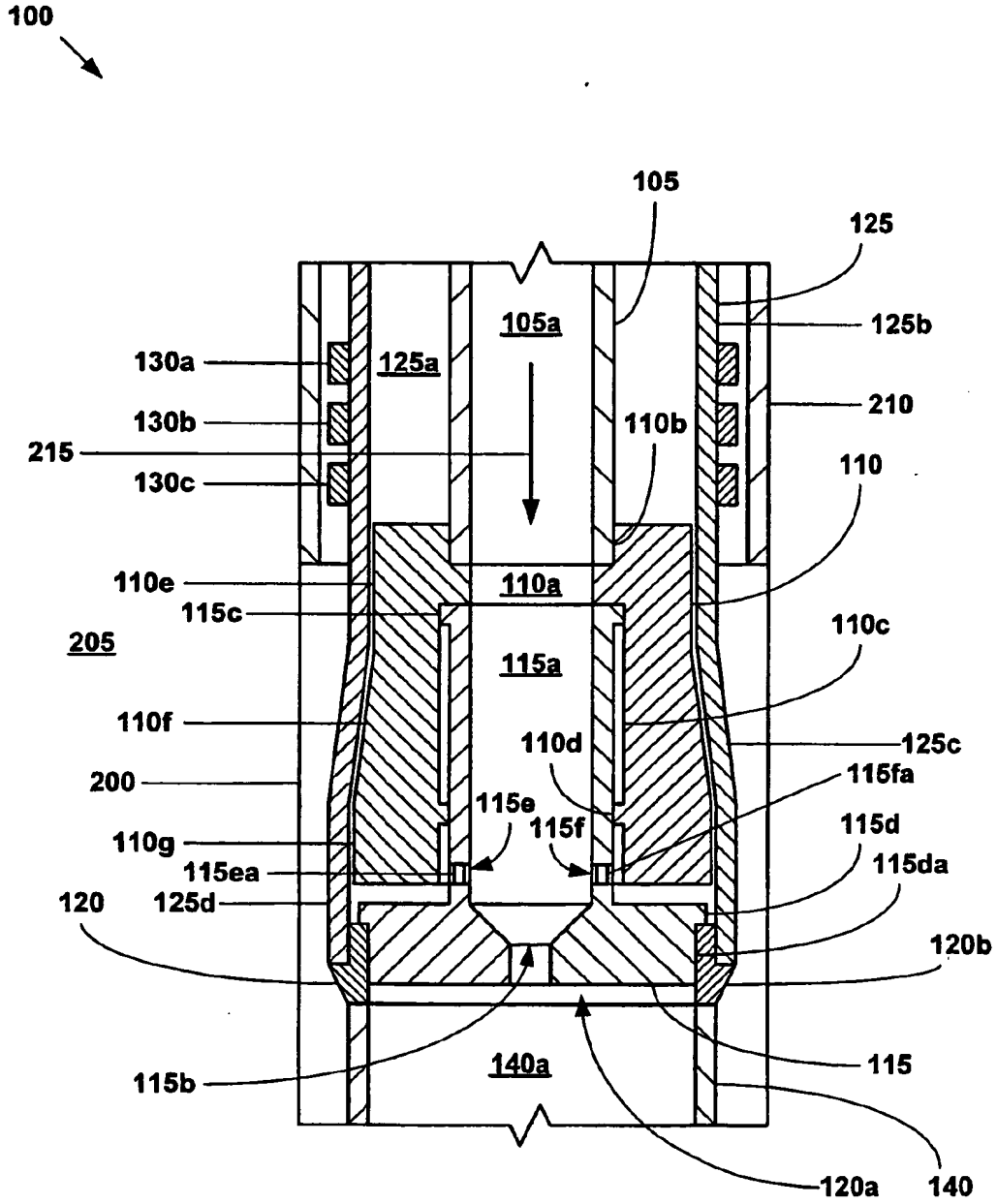

Fig. 2

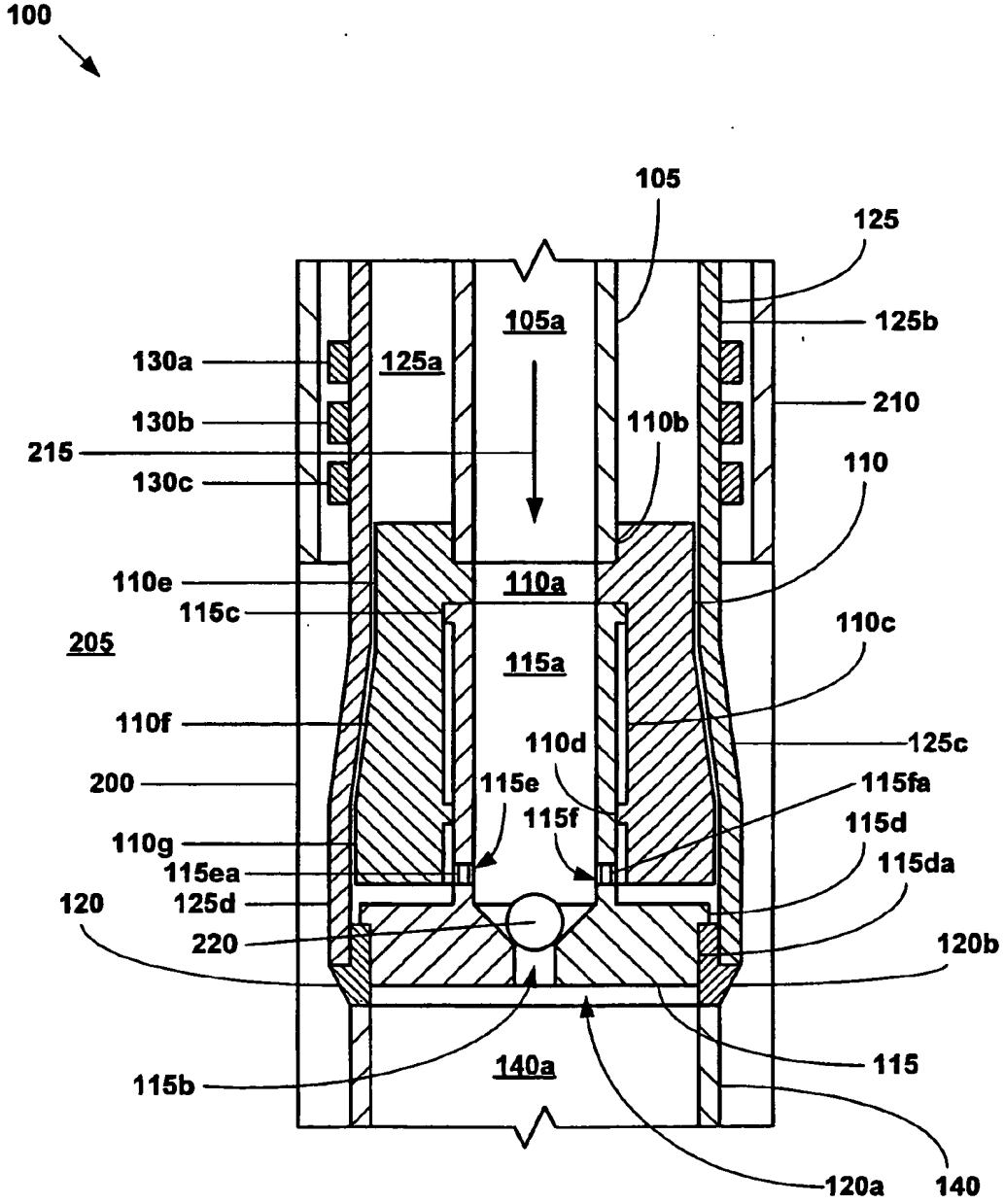

Fig. 3

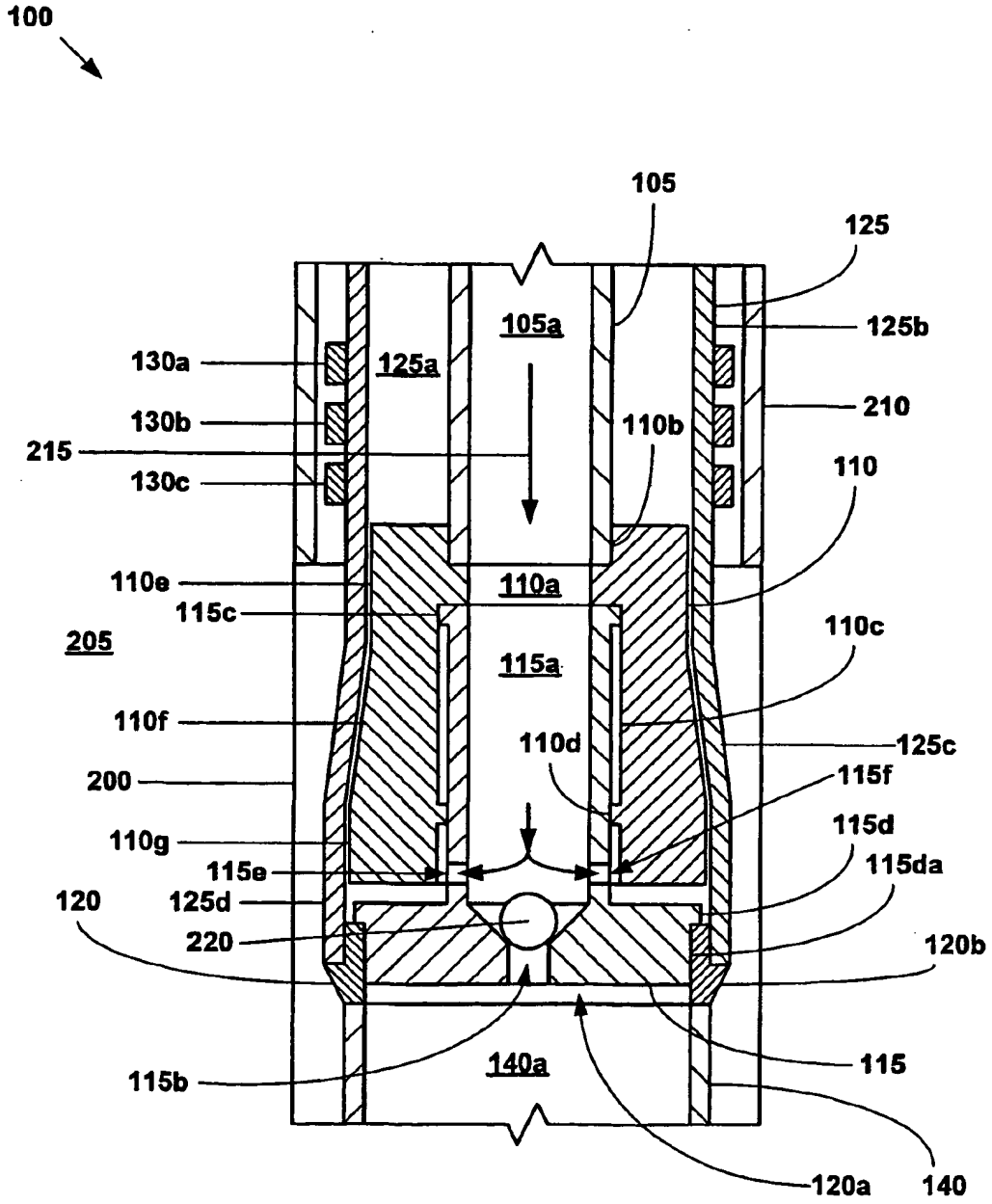

Fig. 4

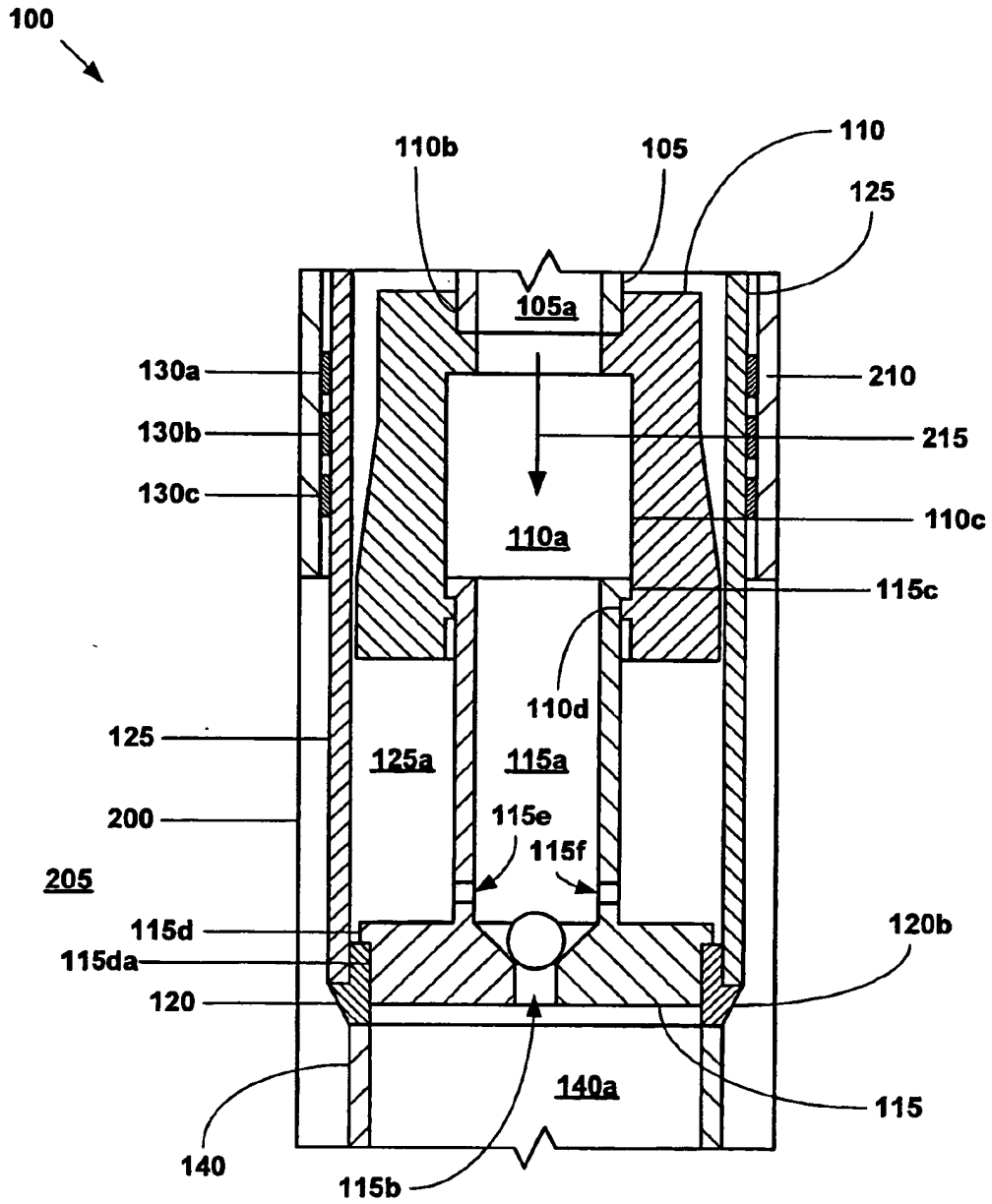

Fig. 5

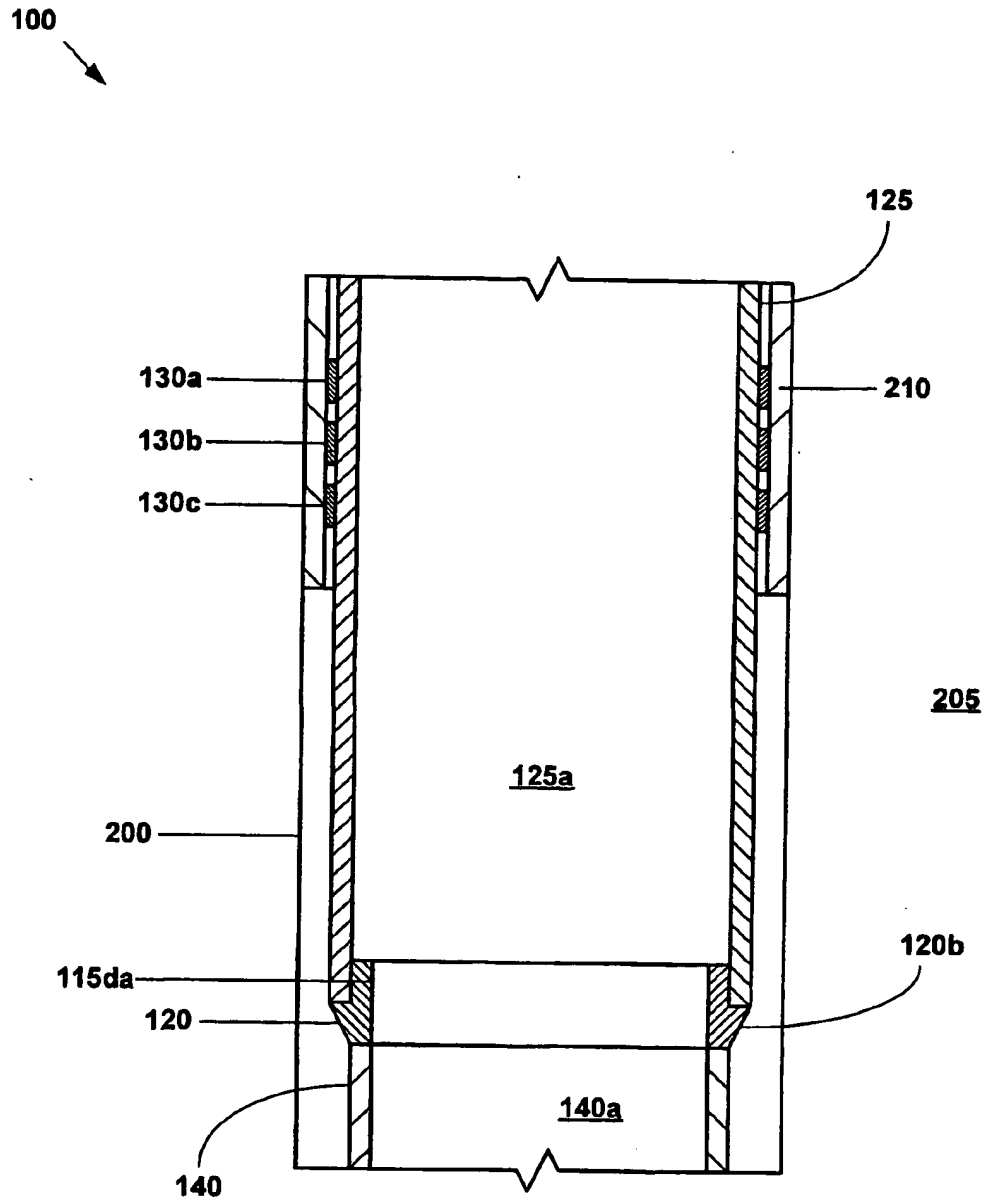

Fig. 6